

## THE FLATHEAD CYLINDRICAL RIVET NUTS

The paragraph rivet nut similar to GB GB/T17880.1-1999 is more commonly used style rivet nuts, corrected according to the actual needs of the customer and our understanding of the product on the basis of the national standard. Flange face increased non-slip teeth, increase the rotational torque, technical parameters exceeded the standard requirements abroad. After years of sustained development, this riveting nut fairly complete specifications and with ample inventory, but the performance is slightly inferior to the flat head timepiece of striated rivet nuts and gradually be replaced. Thread specifications metric M3-M12.

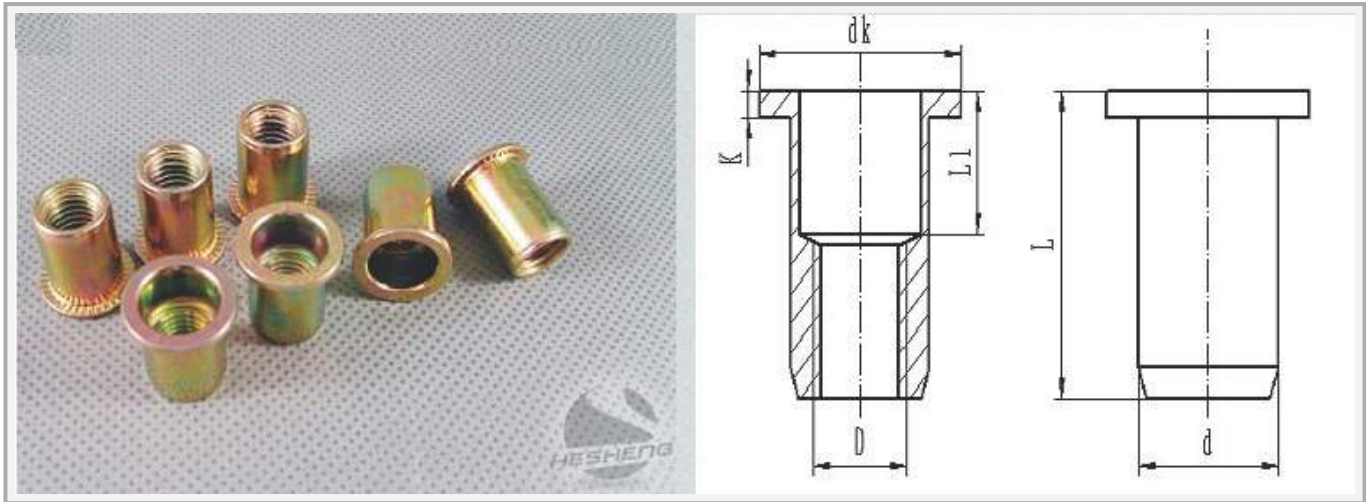

Product Code	D-6h	Dk	K	L	L1	D	Mounting Hole	Riveting Range
HT3-9FRM	M3	7	0.8	9	4.0	4.9	5	0.5-1.5
HT4-11FRM	M4	9	0.8	11	5.0	5.9	6	0.5-2.0
HT5-12FRM	M5	10	1.0	12	6.0	6.9	7	0.5-2.0
HT5-13FRM	M5	10	1.0	13	6.0	6.9	7	0.5-2.0
HT6-15FRM	M6	13	1.3	15	7.0	8.9	9	0.5-2.5
HT6-16FRM	M6	13	1.3	16	8.0	8.9	9	2.0-3.5
HT6-18FRM	M6	13	1.3	18	9.0	8.9	9	3.0-4.0
HT6-19FRM	M6	13	1.3	19	12.0	8.9	9	4.0-7.0
HT8-18FRM	M8	15	1.5	18	8.0	10.9	11	1.0-3.0
HT10-21FRM	M10	17	1.7	21	10.0	12.9	13	2.0-4.0
HT12-25FRM	M12	22	2.0	25	10.0	14.9	15	2.0-4.0