

THE COUNTERSUNK HEAD TIMEPIECE OF STRIATED RIVET NUTS

This riveting nut similar to GB GB/T17880.2-1999 correction according to the actual needs of the customer and the understanding of my company on the basis of the national standard. Antiskid teeth and stripes under the flange surface and the cylindrical surface increases, the larger the increase in rotational torque. Riveting rivet nuts and riveting plate surface was essentially flat. The rivet nut drilling counterbore is not very convenient to use, more commonly used in higher mechanical components. The thread specifications of M4-M12. Of the company's main recommended products.

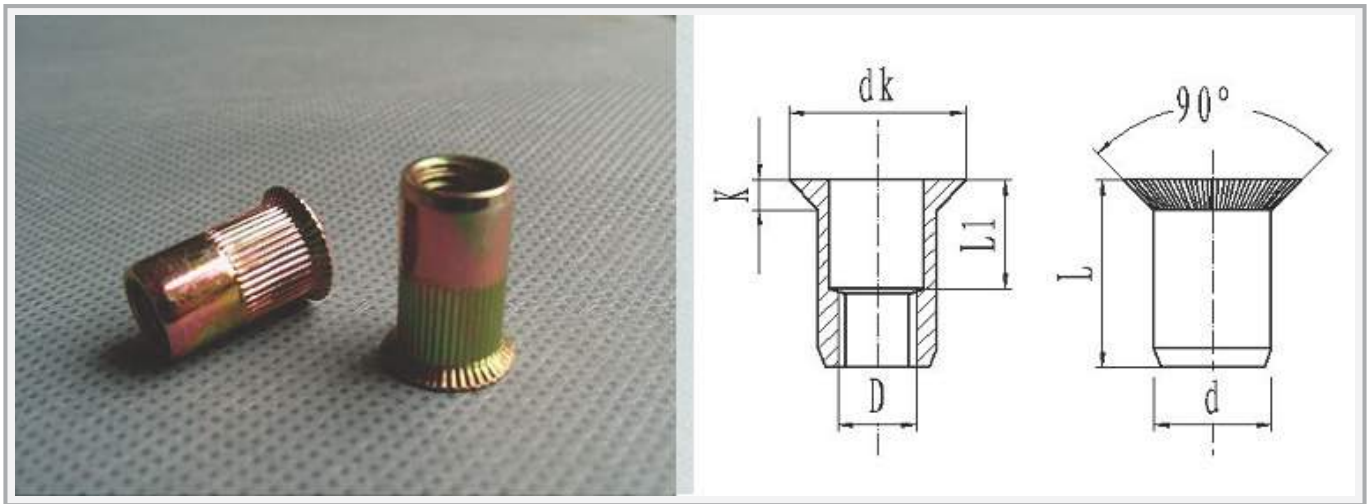

Product Code	D-6h	Dk	K	L1	L	D	Mounting Hole	Riveting Range
HT4-11CKRM	M4	9.0	1.5	5.5	11.0	5.90	6.0	1.6-2.5
HT5-13CKRM	M5	10.0	1.5	6.5	13.0	6.90	7.0	1.6-2.5
HT5-14CKRM	M5	10.0	1.5	7.0	14.0	6.90	7.0	2.5-3.5
HT6-15CKRM	M6	12.0	1.5	7.0	15.0	8.90	9.0	1.6-3.5
HT6-16CKRM	M6	12.0	1.5	8.0	16.0	8.90	9.0	1.6-4.5
HT6-18CKRM	M6	12.0	1.5	10.0	18.0	8.90	9.0	4.0-6.5
HT8-18.5CKRM	M8	14.0	1.5	9.0	18.5	10.9	11.0	2.5-5.0
HT8-19.5CKRM	M8	14.0	1.5	10.0	19.5	10.9	11.0	5.0-6.0