

The paragraph rivet nut similar to GB GB/T17880.1-1999 is the most commonly used style rivet nuts, has been amended in accordance with the actual needs of the customers and the Company's understanding of the product on the basis of the national standard. And cylindrical flange face increased non-slip teeth and vertical stripes, which greatly increase the rotational torque. After years of sustained development, so this rivet nut specification is quite well-equipped with plenty of inventory the the main recommended products for my company. The thread specifications Metric M3-M12, US-made 6 # -1/2UNC.

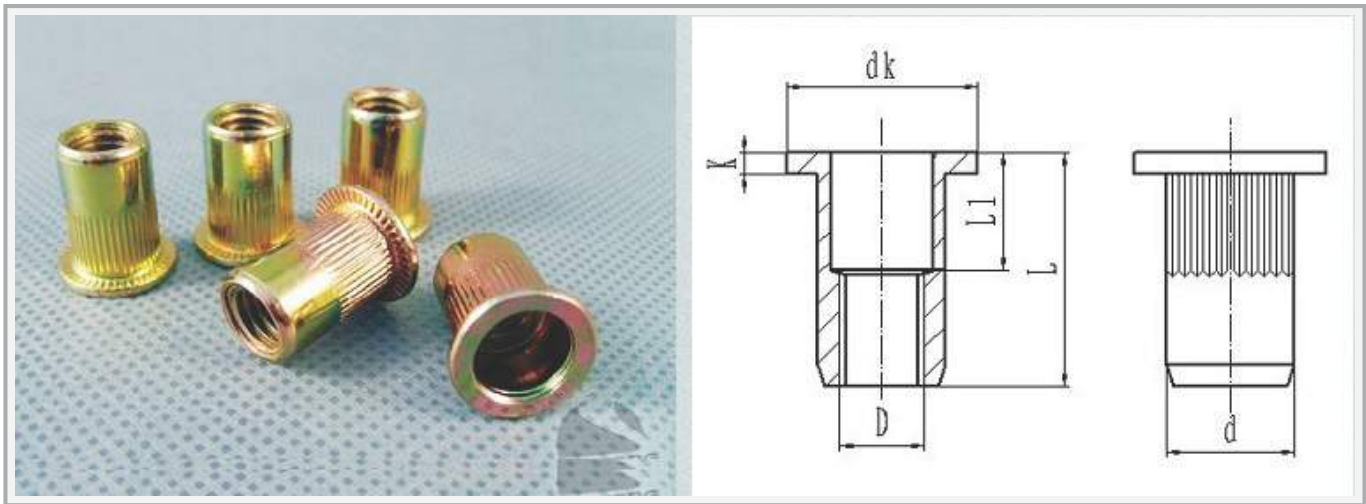

Product Code	D	Dk	K	L	L1	D	Mounting Hole	Riveting Range
HTM3-9FK	M3	8.0	0.8	9.0	5.0	4.9	5.0	0.5-1.5
HTM4-11FK	M4	9.0	1.0	11.0	5.5	5.9	6.0	0.5-2.0
HTM4-13FK	M4	9.0	1.0	13.0	6.5	5.9	6.0	1.5-3.0
HTM4-15.5FK	M4	9.0	1.0	15.5	5.0	5.9	6.0	0.5-1.0
HTM4-16FK	M4	9.0	1.0	16.0	7.0	5.9	6.0	3.0-5.0
HTM5-13FK	M5	10.0	1.0	13.0	6.0	6.9	7.0	0.5-2.5
HTM5-14FK	M5	9.0	1.0	14.0	6.0	6.9	6.0	1.0-3.0
HTM6-10FK	M6	13.0	1.3	10.0	5.0	8.9	9.0	0.5-1.0
HTM6-12FK	M6	13.0	1.3	12.0	5.8	8.9	9.0	0.5-1.5
HTM6-15FK	M6	13.0	1.3	15.0	7.0	8.9	9.0	0.5-2.5
HTM6-16FK	M6	13.0	1.3	16.0	7.5	8.9	9.0	0.5-3.0
HTM6-18FK	M6	13.0	1.3	18	9.0	8.9	9.0	2.5-4.0
HTM6-19AFK	M6	13.0	1.3	19	9.5	8.9	9.0	3.0-4.5
HTM6-19BFK	M6	11.0	1.3	19	7.0	8.9	9.0	0.5-2.5
HTM8-15FK	M8	15.0	1.5	15	6.4	10.9	11.0	0.5-1.2
HTM8-18FK	M8	15.0	1.5	18	8.0	10.9	11.0	0.5-2.5
HTM8-20AFK	M8	15.0	1.5	20	10.5	10.9	11.0	2.5-5.0
HTM8-20BFK	M8	16.0	1.5	20	10.5	10.9	11.0	2.5-4.0
HTM10-21FK	M10	17.0	1.7	21	10.0	12.9	13.0	1.0-4.0
HTM12-25FK	M12	22.0	2.0	25	11.0	12.9	16.0	1.0-5.0
HTUNC10#-13FK	10#-24	10.0	1.0	13	6.5	6.9	7.0	0.5-2.0
HTUNC1/4-15FK	1/4-20UNC	13.0	1.3	15	7.0	8.9	9.0	0.5-2.5
HTUNC5/16-17.5FK	5/16-18UNC	15.0	1.5	17.5	7.5	10.8	11.0	0.5-2.5
HTUNC3/8-20.3FK	3/8-16UNC	17.0	1.7	20.3	10.0	12.9	13.0	1.0-4.0
HTUNC3/8-22FK	3/8-16UNC	18.0	2.0	22	10.0	13.4	13.5	1.5-4.0
HTUNC1/2-29FK	1/2-13UNC			29				